

Differential Pressure Flow Sensors

The Most Accurate and Reliable Technology for Measuring Gas, Liquid and Steam...

Developed from aerospace technology, the Verabar® averaging pitot flow sensor provides unsurpassed accuracy and reliability. With its solid, one-piece construction and bullet shape, the Verabar makes flow measurement leak proof and precise.

The unique sensor shape reduces drag and flow induced vibration. The location of the low-pressure ports eliminates the potential for clogging and improves signal stability.

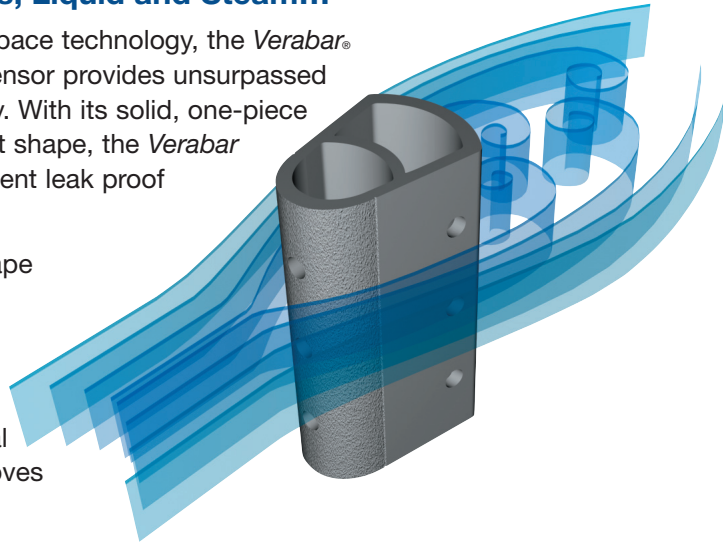

V550 Spring Lock Flanged Connection with Packing Gland

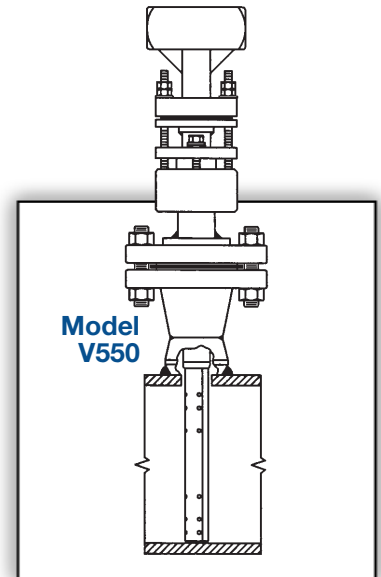

V550 Flanged Spring Lock	
Pipe Connection	Flanged
Mounting Type	Spring loaded sensor mounted on flange with packing gland
Features and Benefits	<ul style="list-style-type: none"> • Blow-out and leak proof design • Preloads sensor to opposite wall • Four times stronger than conventional mountings • Eliminates need for opposite end support • Compensates for changes in pipe diameter due to pressure, temperature or mechanical force • Can mount to existing flanges
Applications	<ul style="list-style-type: none"> • Air • Natural gas • Water (raw, cooling, feedwater) • Hydrocarbon liquids and gases • High velocity fluids • Hazardous fluids • Steam
Special Designs – Consult Factory	<ul style="list-style-type: none"> • Custom mounting, lengths, materials, instrument connections, etc. • Short straight run

Temperature Pressure Limits (ANSI Class)*
150#
275 psig @ 100°F (19 Bars @ 38°C)
80 psig @ 800°F (5.5 Bars @ 426°C)
300#
720 psig @ 100°F (49.6 Bars @ 38°C)
410 psig @ 800°F (28.3 Bars @ 426°C)
600#
1440 psig @ 100°F (99.3 Bars @ 38°C)
825 psig @ 800°F (56.9 Bars @ 426°C)

Model Specifications	V550		
Sensor Code	05	10	15
Sensor Diameter	7/16" (11mm)	7/8" (22mm)	1-3/8" (35mm)
Accuracy	±1% of flow rate; ±0.5% if calibrated		
ANSI Class*	150#, 300# and 600#		
Pipe Size	2"-6" (50mm-150mm)	6"-42" (150mm-1050mm)	12"-60" (300mm-1500mm)
Instrument Connection	1/2" NPT	1/2" NPT or Direct Mount	
Components Furnished	Spring lock mounting assembly, weld coupling, weldneck flange, gasket, studs & nuts		
Flange Size	1"	1-1/2"	2"

* DIN and JIS flanges available. Consult factory.

Verabar® Flanged Models

V550 Spring Lock

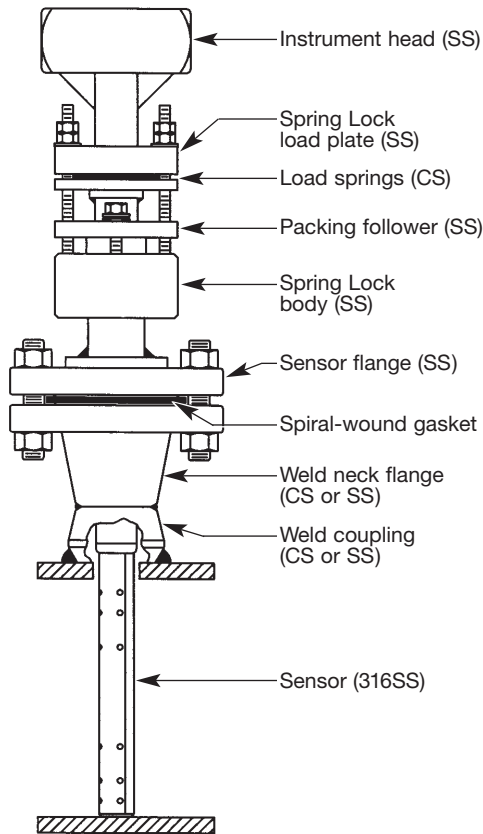

Furnish the following information:

1. Enter Pipe Dimensions or Duct Dimensions

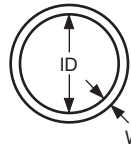

Pipe Size ____ Sch ____
 Pipe ID ____ and
 Wall ____ Pipe Mat'l ____

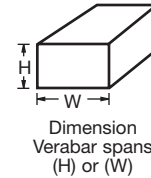

Height (H) ____
 Width (W) ____
 Wall ____
 Duct Mat'l ____

2. Pipe or Duct Orientation

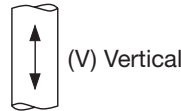
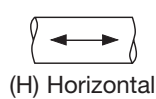

3. Enter Flow Conditions

Fluid Name:		Maximum	Normal	Minimum	Units
Flow Rate					
All Fluids	Temperature @ Flow				
	Pressure @ Flow				
Gas	Specific Gravity, or Molecular Weight				
Liquid	Specific Gravity				
Steam	Veracalc Program can calculate Density from Temperature and Pressure				

4. Select Model from Page 3

Use the Ordering Information table on Page 3 to determine your model number.

5. Flow Calculation



All Verabar applications require a flow calculation to verify the DP, pressure and temperature limits, structural limits and to size the transmitter. The Veracalc PC Program is for use by representatives and end users. It is easy to operate and **includes steam tables**.

Model V550

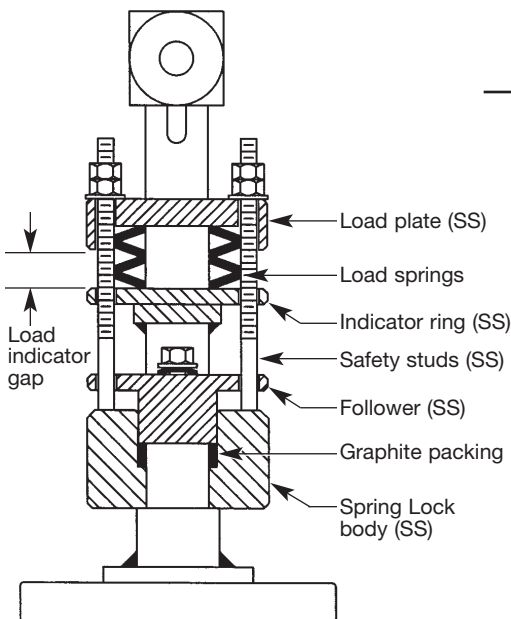

Spring Lock Mount

- Design ensures the sensor is sealed, locked and pre-loaded to the opposite wall, regardless of changes in pipe diameter due to pressure, temperature or mechanical vibrations.
- Leak-proof...compensates for differential in packing and body growth rates due to increased temperatures.
- Increases sensor strength (eliminates the need for an opposite wall support). A locked, pre-loaded sensor is four times stronger than a non pre-loaded, cantilevered sensor.
- Spring Lock is engineered with three standard spring configurations equivalent to ANSI class 150#, 300# and 600# ratings.
- By loading the sensor and packing independently, the sensor can move axially to maintain a precise load on the pipe wall.

Ordering Information

Model	Flanged						
V550	Spring Lock						
Pipe Size and Schedule or Exact ID and Wall Thickness							
Code	Sensor Pipe Size Range						
05	2" to 6" (50mm to 150mm)						
10	6" to 42" (150mm to 1050mm)						
15	12" to 60" (300mm to 1500mm)						
Code	Pipe Orientation						
H	Horizontal						
V	Vertical						
Instrument Connections (Select Remote or Direct Mount) (Transmitter sold separately)							
Remote Mount Transmitter (1/2" NPT)				Direct Mount Transmitter (Flanged 450°F/232°C Max.)†			
Parallel	Regular	RTD*	Valve	Transmount	Mass Transmount*	Manifold	
		 Explsn. Proof	 Integral		 Integral RTD	 Remote RTD	 Integral
P	R	D	T	F	G	E	M
Instrument Valves (Opt.)				Manifolds (Optional)			
Remote Mount				Direct Mount			
Needle	Gate	3-Valve		5-Valve			
1/2" NPT	1/2" NPT	Soft Seat	Hard Seat	Soft Seat	Hard Seat		
C2NC (CS) C2NS (SS)	C2GC (CS) C2GS (SS)	F3SC (CS) F3SS (SS)	F3HC (CS) F3HS (SS)	F5SC (CS) F5SS (SS)	F5HC (CS) F5HS (SS)		
Mounting Assembly – Select Material & Rating (Includes SS sensor flange, WN flange, weld coupling, spiral-wound gasket, studs & nuts)							
Sensor (Flange Size)						Mating Flange Material & ANSI Class	
05 (1")	10 (1-1/2")	15 (2")					
Code							
F415C F415S	F615C F615S	F815C F815S				CS	150#
						SS	150#
F430C F430S	F630C F630S	F830C F830S				CS	300#
						SS	300#
F460C F460S	F660C F660S	F860C F860S				CS	600#
						SS	600#
V550	8"sch40	10	H	R	C2NC	F615C	Typical Model Number

* For high pressure (>500psig) or high temperature (>500°F), remote mount RTD in a thermowell is preferred.

† Assuming adequate heat dissipation for transmitter.

REMOUNT CODE	PARALLEL	REGULAR	RTD	VALVE	NEEDLE	GATE
P	1/2" NPT	1/2" NPT	X PROOF	INTEGRAL	1/2" NPT	1/2" NPT
R	1/2" NPT					
D						
T						
S						
C2NC (CS)						
C2NS (SS)						
C2GC (CS)						
C2GS (SS)						

DIAGNOSTIC CODE	TRANSMOUNT	MASS TRANSMOUNT	MANIFOLD	MANIFOLDS		
F				3-VALVES	5-VALVES	
G				SOFT SEAT	SOFT SEAT	
E				HARD SEAT	HARD SEAT	
M				F3SC (CS)	F5SC (CS)	
				F3SS (SS)	F5SS (SS)	
				F3HC (CS)	F5HC (CS)	
				F3HS (SS)	F5HS (SS)	

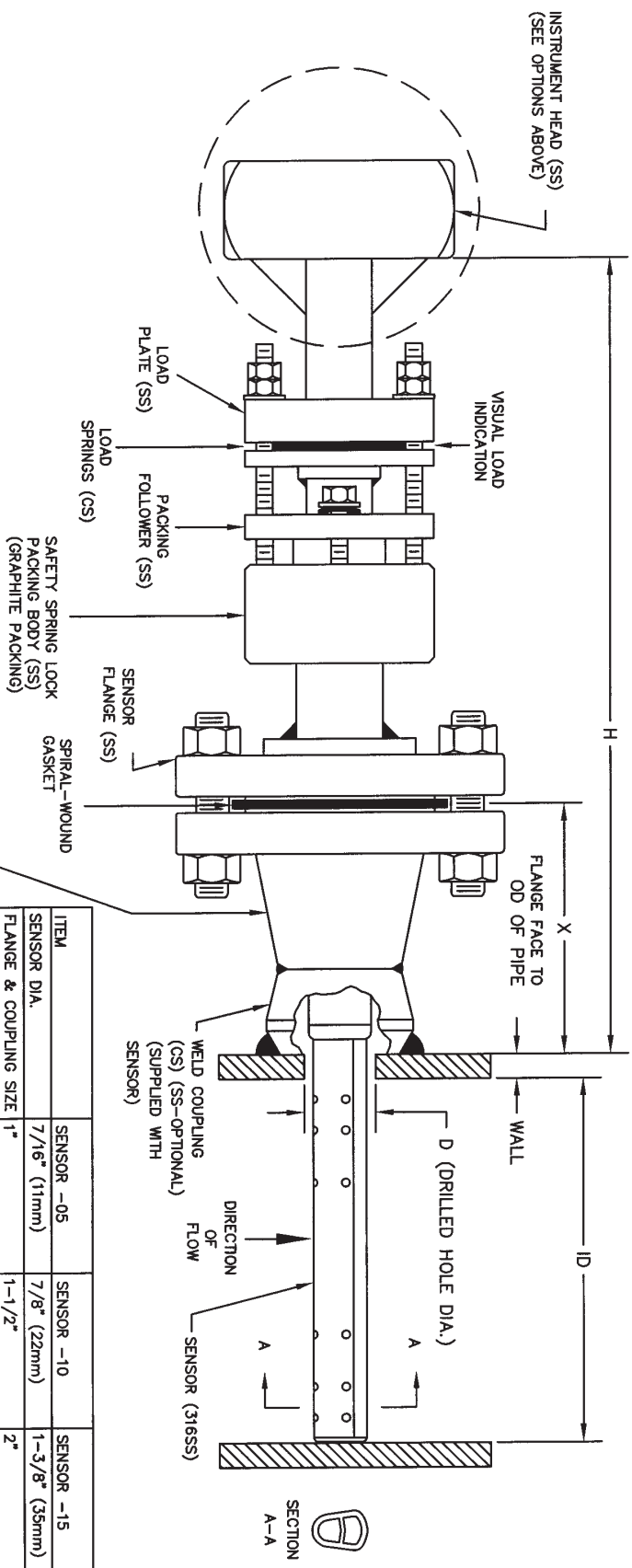

ITEM	SENSOR -05	SENSOR -10	SENSOR -15
SENSOR DIA.	7/16" (11mm)	7/8" (22mm)	1-3/8" (35mm)
FLANGE & COUPLING SIZE	1"	1-1/2"	2"
DIM "D" DRILLED HOLE DIA.	1/2" (13mm)	1" (26mm)	1-1/2" (39mm)
DIM "H" ANSI CLASS 150#	11.4" (289mm)	14.5" (368mm)	16.8" (427mm)
DIM "H" ANSI CLASS 300#	12.0" (305mm)	15.1" (383mm)	17.4" (441mm)
DIM "H" ANSI CLASS 600#	12.5" (317mm)	15.7" (399mm)	18.1" (460mm)
DIM "X" ANSI CLASS 150#	3.31" (84mm)	3.81" (97mm)	4.06" (103mm)
DIM "X" ANSI CLASS 300#	3.56" (90mm)	4.06" (103mm)	4.31" (110mm)
DIM "X" ANSI CLASS 600#	3.81" (97mm)	4.38" (111mm)	4.69" (119mm)

* "H" & "X" DIMENSIONS ARE APPROXIMATE (FOR SIZING PURPOSES ONLY)

CUSTOMER: _____
PROJECT: _____
ORDER NO: _____
TAG NO: _____
PIPE SIZE & SCHEDULE: _____
CATALOG NO: _____
SERIAL NO: _____
CERTIFIED BY: _____ DATE: _____

VERIS, inc.
6315 MONARCH PARK PLACE
NIWOT, CO 80503
PHONE: 303-652-8550
FAX: 303-652-8552

VERABAR MODEL: V550
SPRING LOCK FLANGED

DATE 09/20/01 DWG NO. SUB-3943
SCALE NTS REV A PAGE 1 OF 1