

1.0 SCOPE

These instructions provide procedures for installing the V500 and V510 Verabar flow sensor. Procedures are given for all industrial flow measurement applications including liquid, steam and gas service for both horizontal and vertical piping configurations.

2.0 RECEIVING INSPECTION

The following tasks should be performed as part of the receiving inspection procedure:

- Check items received against the packing list.
- Check sensor nameplate for proper model number, serial number and customer number.
- Verify that the actual pipe diameter matches the ID stated on the sensor nameplate.
- Check the bullet shaped sensor tube for any signs of damage. Damage to the sensor tube may result in erroneous flow readings.
- Check the round cover tube for any damage, especially axial gouges or scratches. Damage to the cover tube may prevent the ferrule from sealing properly.

3.0 SAFETY PRECAUTIONS

The following tasks should be conducted prior to installing the Verabar flow sensor:

- Check maximum operating conditions on the flow sensor nameplate and verify that they exceed the maximum conditions of the installation. If any pressure, temperature or flow limits will be exceeded, consult the factory before proceeding.

- Check that the pipe is depressurized and drained prior to installation.
- Check that all pressure containing components are properly installed and tightened prior to pressurizing the system.

4.0 INSTALLATION PREPARATIONS

4.1 Location

For the most accurate flow measurement, a minimum straight run of pipe is required. Table 1 shows the minimum straight run requirements. If longer straight runs are available, position the Verabar such that the ratio of upstream straight run to downstream straight run is approximately 4 to 1. If straight run lengths are less than the values stated in Table 1, consult the factory for additional accuracy and location information. For additional piping configurations, see Drawing SUB-4521.

Position straightening vanes such that the end closest to the Verabar is half way between the Verabar and the closest upstream configuration. For elbow installations, mount the Verabar in the same plane as the closest upstream elbow.

4.2 Orientation

Verify the proper sensor orientation by checking for an "H" (horizontal piping) or a "V" (vertical piping) in the model number on the Verabar nameplate. Verify the flow arrow stamped on the instrument head is pointing downstream in the direction of the flow.

Piping Configuration	Dimension -A-		Dimension -B-	
	Without Straightening Vanes	With Straightening Vanes		
Elbow		7	7	3
Multiple Elbows in the Same Plane		9	9	3
Multiple Elbows in Different Planes		18	9	3
Reduction in Pipe Size		8	8	3
Increase in Pipe Size		8	8	3
Control Valve		24	9	4

Table 1. Straight Run Requirements

4.2.1 Horizontal Piping

For air or gas installations, mount the Verabar in the upper 160° of the pipe to allow any condensate to drain into the pipe (Figure 1). For liquid or steam installations, mount the Verabar in the lower 160° of the pipe. This allows any entrained air to bleed back into the pipe for liquid applications and allows condensate to collect in the instrument piping for steam applications.

4.2.2 Vertical Piping

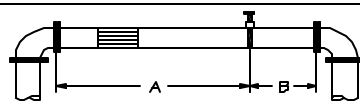
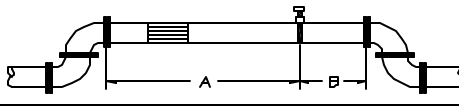
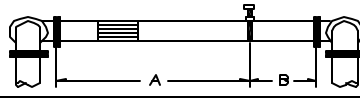
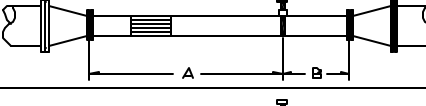
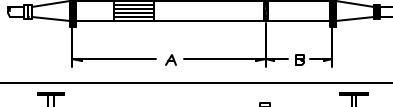
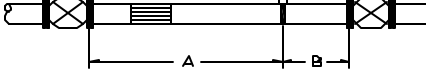
The Verabar may be mounted in any location around the circumference of the pipe for any vertical piping applications (Figure 1).

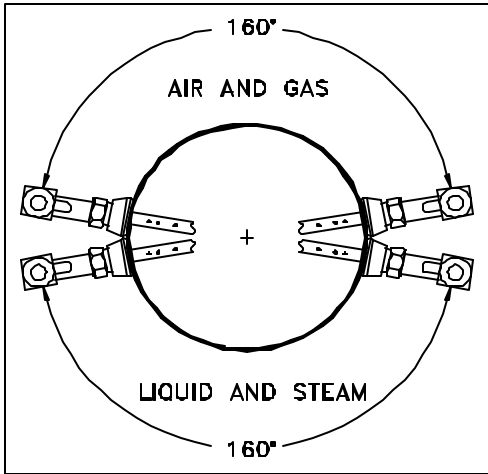

Figure 1. Verabar Orientation in Horizontal Pipe

4.3 DP Transmitter/Local Indicator Location

When choosing a Verabar location, consider the DP transmitter/local indicator location:

- The transmitter must be mounted below the Verabar for liquid and steam applications.
- The transmitter must be mounted above the Verabar for air and gas applications.

4.4 Installation Drawings and Bill of Materials

Additional information is available in the Installation Drawings and Bill of Materials VB-7061 (also on the VeraData CD). It contains standard and alternate transmitter locations and a complete bill of materials based on the fluid type and sensor orientation on the pipe.

5.0 INSTALLATION PROCEDURE

5.1 Drill Hole in Pipe

- Completely depressurize and drain pipe prior to installation of the Verabar.
- Mark the location of the hole through which the Verabar will be mounted. For V510 models, mark the location of the opposite end of the side support 180° from the first hole. Use a center punch to mark the holes to prevent the drill bit from walking on the pipe.
- Drill the pipe with the proper sized hole per the following table:

Sensor Size	Hole Dia
V500-05 & V510-05	1/2" (13mm)
V500-10 & V510-10	1" (25mm)
V500-15 & V510-15	1-1/2" (38mm)

- Deburr the hole(s) on the inside of the pipe.

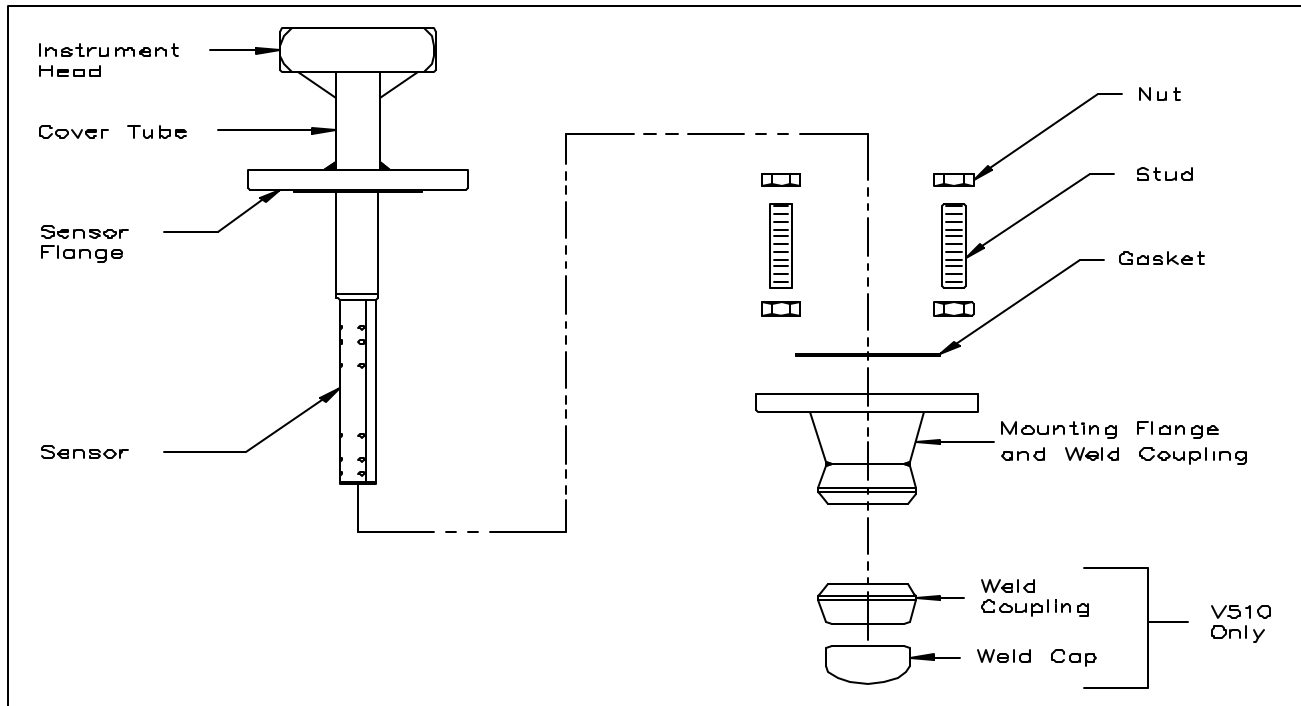

Figure 2. Verabar Model V500 and V510

5.2 Weld Mounting Flange to Pipe

- Loosely bolt together (hand tight) the sensor, gasket and mounting flange. Insert the assembly into the pipe. Align the head of the sensor so that the arrow labeled "flow" on the head is in the direction of the flow to within 3°. The contour of the weld coupling should match the contour of the pipe. Check that the bottom of the weld coupling is in contact with the pipe wall.
- Using the appropriate weld gap (1/16" [1.5mm] typical), tack weld the mounting flange into position (Figure 3).

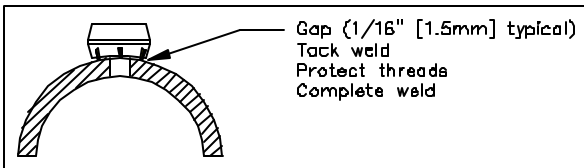

Figure 3. Weld Gap

- Note the flange orientation per Figure 4. The bolt holes on the flange should straddle the centerline of the pipe (2-holing pattern). For V510 models, slide the opposite end weld coupling over the tip of the sensor and tack weld into position.
- Remove the sensor and finish welding the weld coupling(s) per applicable piping codes. For V510 models, weld the weld coupling and weld cap into position.

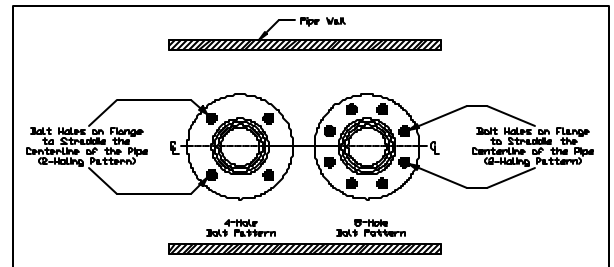

Figure 4. Flange Orientation

5.3 Insert Sensor

Install the sensor with the gasket between the flanges such that the flow arrow on the head of the sensor is in the direction of the flow (Figure 5). The nuts should be tightened until the gasket is completely crushed (the gasket thickness should be approximately 1/8" [3mm]).

5.4 Insert Instrument Valves or Manifold

5.4.1 Valves

If the Verabar does not have a valve head, install instrument valves using proper thread sealant. Be sure instrument shut-off valves are installed and shut prior to repressurizing the pipe.

5.4.2 Manifold

If the Verabar has a direct or integral manifold, be sure the high and low pressure block valves are shut off prior to repressurizing the pipe.

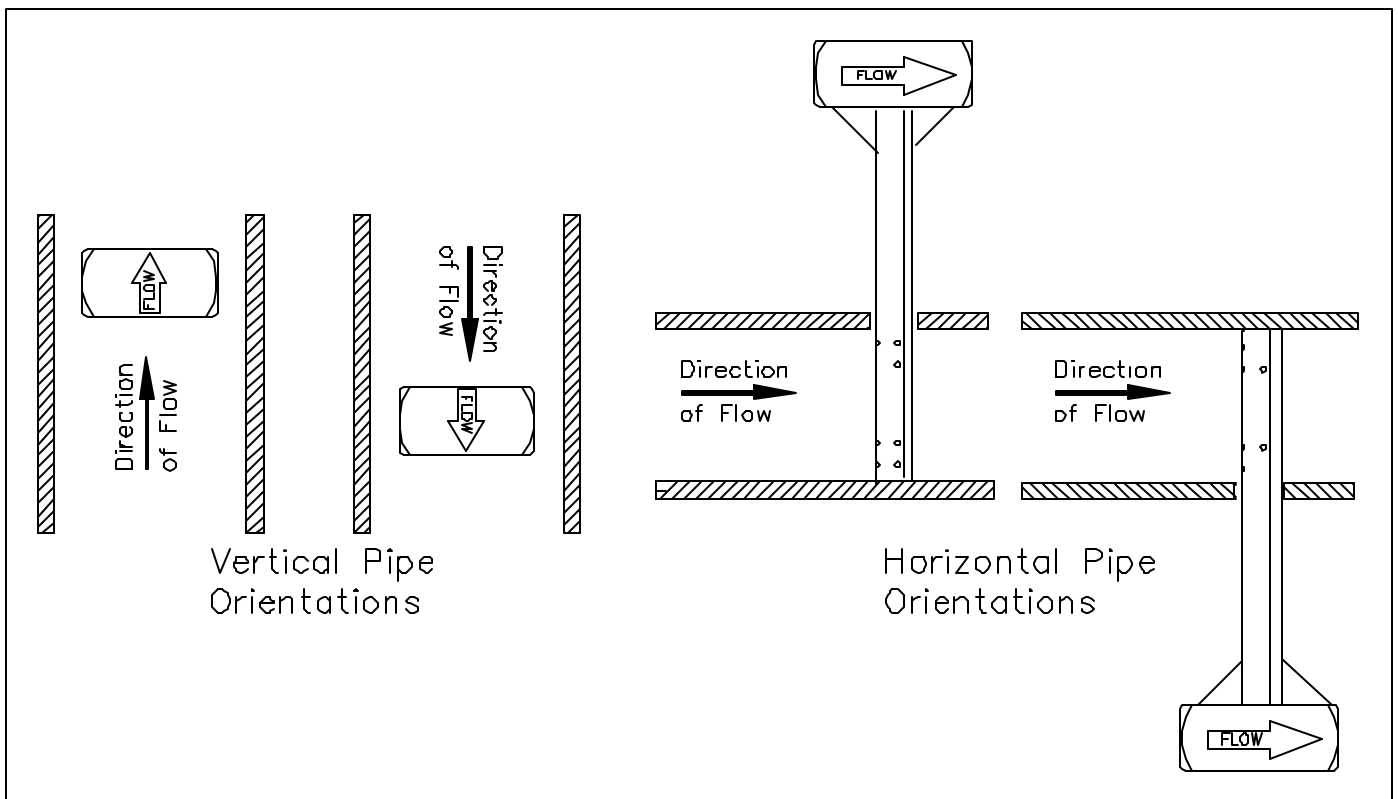

Figure 5. Orientation of Flow Arrow

The Verabar is now properly installed (Figure 6).

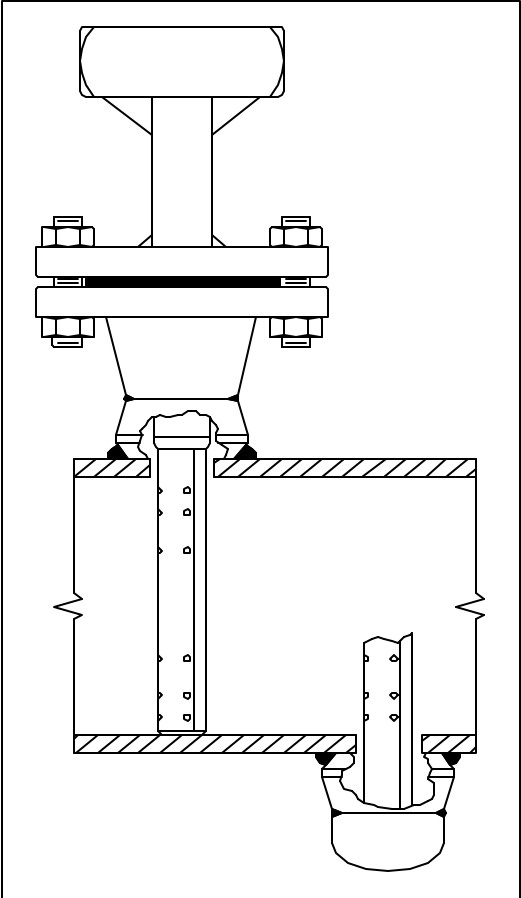

Figure 6. Installed V500 and V510